

Hybrid Aluminum Electrolytic Capacitors

NSPE-U Series

- CYLINDRICAL V-CHIP CONSTRUCTION FOR SURFACE MOUNTING
- HIGH TEMPERATURE RANGE (+125°C)
- ULTRA LOW ESR AND HIGH RIPPLE CURRENT
- 8x10.8 ~ 10x10.8mm CASE SIZES
- REFLOW SOLDERING RATED TO +260°C (see reflow specifications)

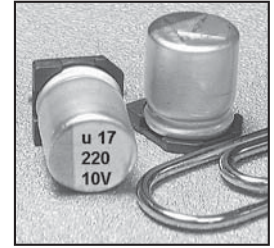

**RoHS
Compliant**

includes all homogeneous materials

*See Part Number System for Details

CHARACTERISTICS

Rated Voltage Range	6.3 ~ 16Vdc			
Rated Capacitance Range	22 ~ 560 μ F			
Operating Temp. Range	-55 ~ +125°C			
Capacitance Tolerance	\pm 20% (M)			
Max. Leakage Current After 2 Minutes @ 20°C	See Specifications Tables			
Working and Surge Voltage Ratings	W.V. (Vdc)	6.3	10	16
	S.V. (Vdc)	8.2	13	20
Tan δ @ 120Hz/20°C		0.18	0.16	0.14
Impedance Ratio	Z -55°C/Z +20°C	1 ~ 2.5		
	Z +125°C/Z +20°C	0.5 ~ 1.0		
Load Life Test @ 125°C and Rated Voltage	W.V. (Vdc)	6.3	10	16
	Case Dia. ϕ 8 & 10mm	2000 hrs.		
	Capacitance Change	Within \pm 30% of initial measured value		
	Tan δ and ESR	Less than 200% of specified max. value		
	Leakage Current	Less than specified max. value		
	ESR	Less than 200% of specified max. value		

STANDARD PRODUCTS AND CASE SIZES D ϕ x L (mm)

PART NUMBER	Cap. (μ F)	Working Voltage	Case Size (D X L) mm	Max. Tan δ 120Hz/20°C	Max. LC (μ A) AFTER 2 MIN.*	Max. ESR (m Ω) AT 100KHz/20°C	Max. Ripple Current (mA rms) AT 100KHz/125°C	Load Life Hours (+125°C)
NSPE-U391M6.3V8X10.8LBF	390	6.3	8X10.8	0.18	492	17	1780	2000
NSPE-U471M6.3V10X10.8LBF	470		10X10.8	0.18	593	16	2190	2000
NSPE-U561M6.3V10X10.8LBF	560		10X10.8	0.18	706	16	2190	2000
NSPE-U101M10V8X10.8LBF	100	10	8X10.8	0.16	200	20	1680	2000
NSPE-U221M10V8X10.8LBF	220		8X10.8	0.16	440	18	1680	2000
NSPE-U391M10V10X10.8LBF	390		10X10.8	0.16	780	17	2060	2000
NSPE-U220M16V8X10.8LBF	22	16	8X10.8	0.14	100	28	1380	2000
NSPE-U330M16V8X10.8LBF	33		8X10.8	0.14	106	26	1380	2000
NSPE-U470M16V8X10.8LBF	47		8X10.8	0.14	151	24	1380	2000
NSPE-U680M16V8X10.8LBF	68		8X10.8	0.14	218	22	1380	2000
NSPE-U101M16V10X10.8LBF	100		10X10.8	0.14	320	19	1850	2000

For Automotive Applications See Part Numbering System

*Please review typical leakage current performance, as shown on NIC load life endurance test report.

RIPPLE CURRENT FREQUENCY CORRECTION FACTORS

Cap. μ F	100Hz	1KHz	10KHz	100KHz
C < 10	0.05	0.20	0.50	1.00

PART NUMBER SYSTEM

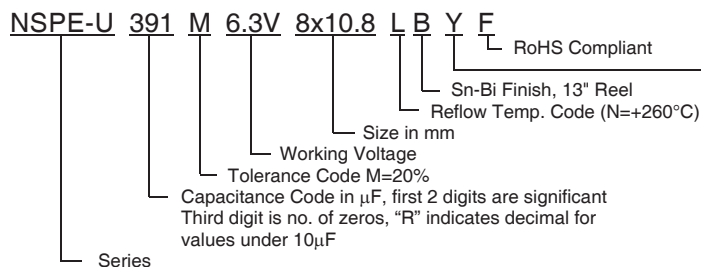

Optional: Suitable for automotive equipment, sourced to special production and inspection at TS-16949 certified production site

PRECAUTIONS

Please review the notes on correct use, safety and precautions found on pages T10 & T11 of NIC's Electrolytic Capacitor catalog.
Also found at www.niccomp.com/precautions
If in doubt or uncertainty, please review your specific application - process details with NIC's technical support personnel: tpmg@niccomp.com



DIMENSIONS (mm)

Case Size	D ϕ ± 0.5	L max.	A, B ± 0.2	W	I ± 0.2	P ± 0.2
8x10.8	8.0	10.8	8.3	0.7 ~ 1.0	2.9	3.2
10x10.8	10	10.8	10.3	1.0 ~ 1.4	3.2	4.6

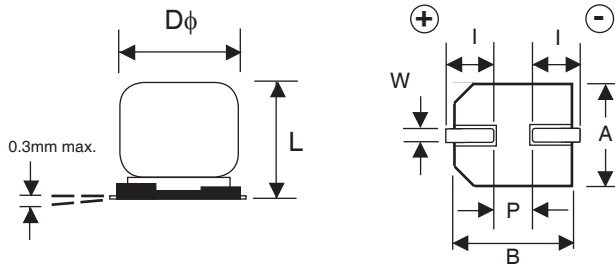

Part Marking

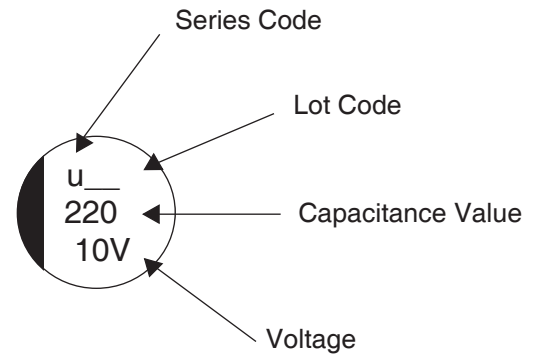

RECOMMENDED REFLOW SOLDERING PROFILE

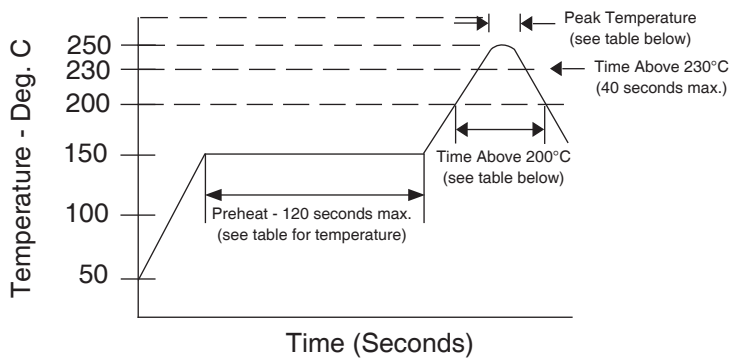

LAND PATTERN DIM. (mm)

Case Dia.	A	B	P
8	4.1	2.1	2.8
10	4.4	2.5	4.3

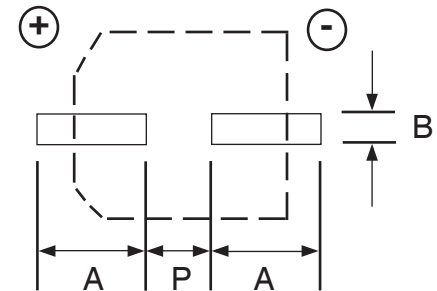

PEAK TEMPERATURE AND DURATION

Diameter	Preheat (120 sec. max.)	Time above 200°C	Time above 230°C	Peak Temperature	Number of Reflow Passes
6.3 ~ 10mm	150°C ~ 190°C	90 sec. max.	40 sec. max.	250°C/5 sec.	2x*
	150°C ~ 180°C	60 sec. max.	40 sec. max.	260°C/5 sec.	1x

*Two reflow passes are permissible with a cool down to room temperature required between the first and second pass.

TAPING SPECIFICATIONS (mm)

- Both Leader and Trailer tape: Minimum 40mm (1.57") empty carrier tape pockets.
- Leader tape: Approximately 20cm of cover tape at leader.
- Connection: Maximum 3 connections (slices) per reel.

Case Size	A	B	C	D	P	T	t
8x10.8	± 0.5	± 0.5	± 0.3	± 0.1	± 0.1	± 0.2	max.
10x10.8	8.7	8.7	24.0	11.5	16.0	11.0	0.6
10x10.8	10.7	10.7	24.0	11.5	16.0	11.0	0.6

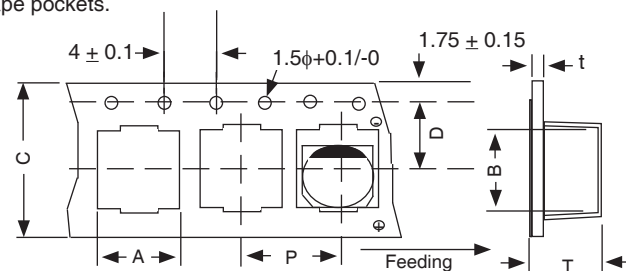

REEL DIMENSIONS (mm)

Case Size	W	Qty per Reel
8x10.8	± 1.0	13" (330mm)
8x10.8	26	300
10x10.8	26	300

